

## Additional Features

## | Drop-in Tank Liners

Each Flexi-Liner is manufactured to meet a customer's unique specification. Various nozzle types can be fabricated to assure a liquid-tight lining.

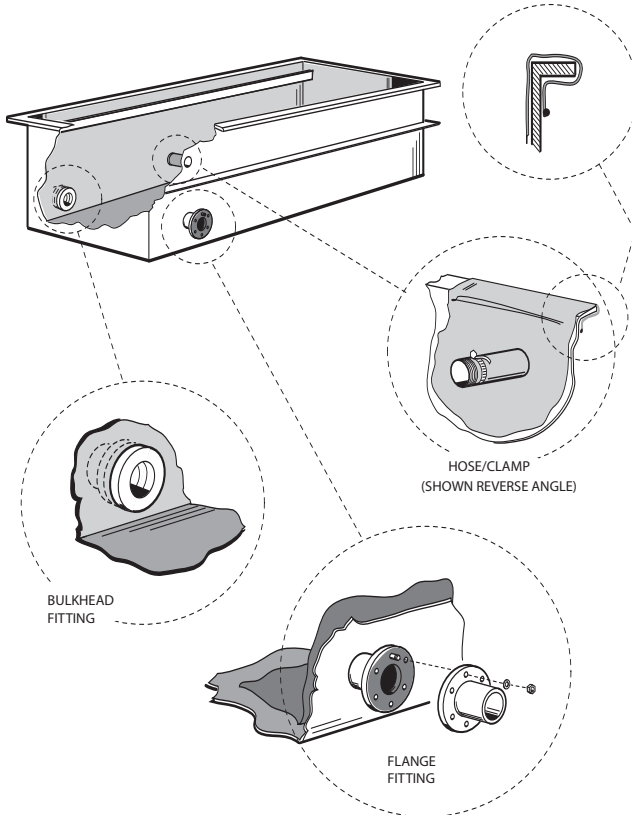

The Sleeve & Cord method of attachment is a simple and cost-effective design to keep the liner in position.

Internal and/or external penetrations are designed to ensure a liquid-tight liner.

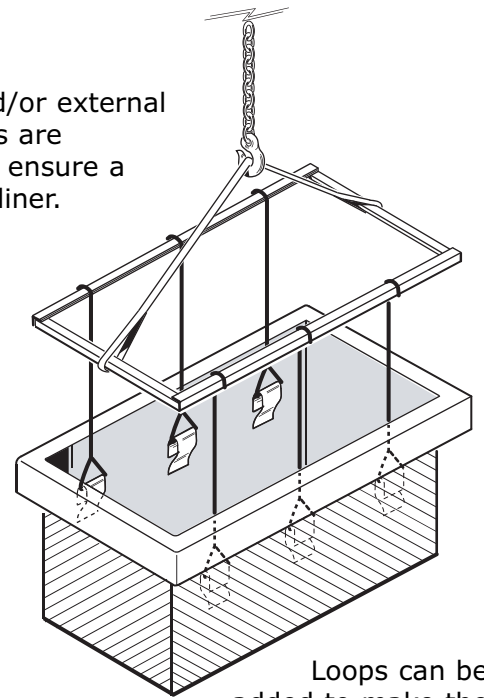

Loops can be added to make the installation more manageable. Assist Loops can be removed or left in place.

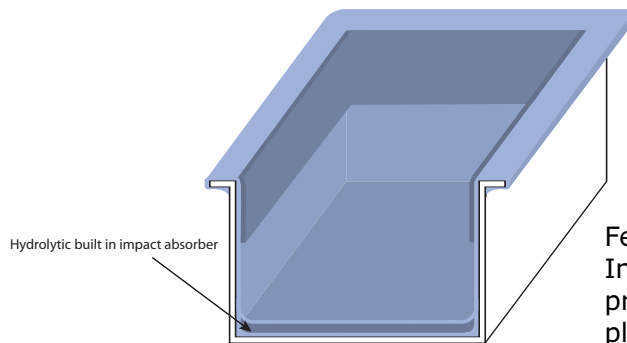

Features that provide additional protection include an Interphase Protector (sacrificial layer), and impact protection such as hydrolytic bottom and impact plates.

**New Life for Old Tanks, Long Life for New Tanks**